

# TC5E Hot-Runner Temperature Controller

---

## *USER'S MANUAL*



Ver.:TC5E-1.0.5

VNA000008

長新科技股份有限公司 ARICO Technology Co., Ltd.

保有權利於任何時間未經通知而修改或變更本手冊內容及型式，未經本公司同意，不得作任何形式的使用。  
reserves the right to make any kind of design or functional modification at any moment without prior notice.





For avoid wrong operation to make human injured or machine damage,  
please read this instruction carefully before use the instrument.

# CONTENT

## Chapter 1 TC5E TEMPERATURE CONTROL MODULE

1-1	Features	2
1-2	Specification	2
1-3	Faceplate	3
1-4	Operating description	5

## Chapter 2 CABINET & ACCESSORIES

2-1	Dimension	9
2-2	Specification	10
2-3	Connection description	10
2-4	Type of power wiring	11
2-5	Connector wiring	13

## Chapter 3 ORDER CODERING

3-1	Cabinet	16
3-2	Cable	16
3-3	Housing	17
3-4	Hood	17
3-5	Blank Plate	17
3-6	Connector	17
3-7	Trouble shooting	18

# Chapter 1 TC5E TEMPERATURE CONTROL MODULE

## 1-1 Features

- Dual SV temperature control
- Dual lines LED display
- Unit display
- Auto/Manual function
- PID auto temperature control
- Selectable two thermocouple types (J or K)
- Selectable two temperature scales (°C or °F)
- Selectable six alarm modes
- Selectable two trigger output modes (Zero cross or phase angle)
- Fuse break indicator
- Power frequency auto-detect
- Thermocouple break and inverse detect
- Thermocouple range K TYPE:0~600°C(32~999°F) / J TYPE:0~600°C(32~999°F)

## 1-2 Specification

- Power input: 230VAC±15%
- Power frequency: 50 / 60Hz
- Power consumption: 7W (each module)
- Input impedance: 10MΩ
- Output wattage: 3600W, 15A / 240VAC
- Storage temperature: -20 ~ 70°C
- Work temperature: 0 ~ 50°C
- Work humidity: 10~80%RH. (non-condensing)
- Control accuracy: ±0.25%FS
- Measure accuracy: ±0.25%FS

# 1-3 Faceplate

## 1-3-1 Faceplate description

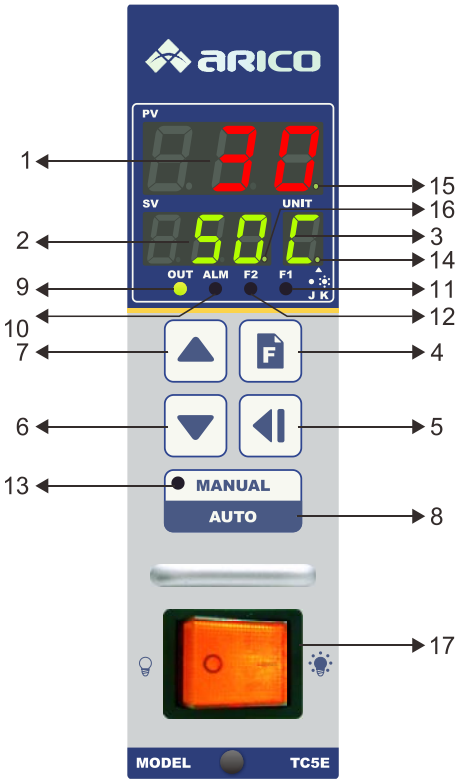

- (1)PV:①Normal mode: Present value  
②Parameter mode: Parameter name
- (2)SV:①Normal mode: Setting value  
②Parameter mode: Parameter value  
③Manual output mode: Manual output %
- (3)UNIT: Temperature or parameter unit
- (4)Function key: Parameter level and parameter select key
- (5)Set key: Set enable and digital shift key
- (6)Decrement key: Setting number decrease
- (7)Increment key: Setting number increase
- (8)Auto/Manual mode key
- (9)Output indicator: Light up when instrument output
- (10)Alarm indicator: Light up when alarm happen
- (11)Fuse 1 indicator: Light up when fuse 1 break
- (12)Fuse 2 indicator: Light up when fuse 2 break
- (13)Manual mode indicator: Light up when instrument is in manual mode
- (14)Sensor input indicator: Light up when K type was selected
- (15)PID tuning indicator: In PID tuning progress indicator flash
- (16)SV2 indicator: Execute SV2 temperature control indicator flash
- (17)Power switch

### 1-3-2 Faceplate appearance and dimension

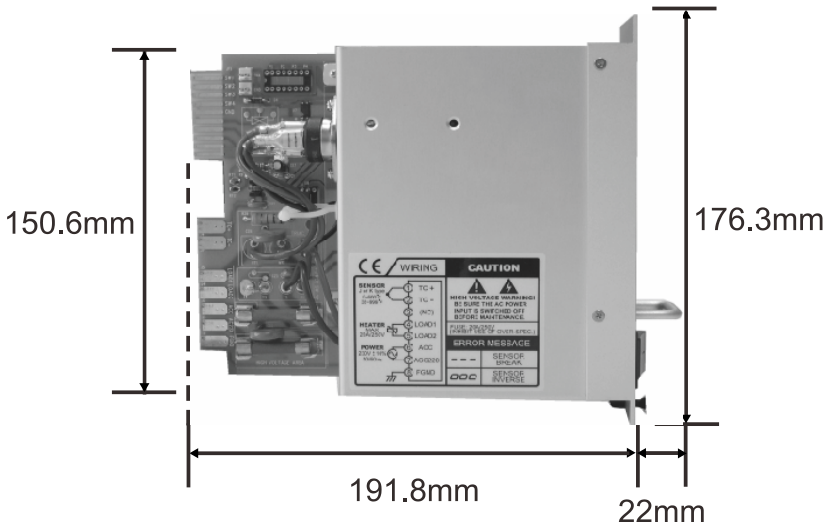
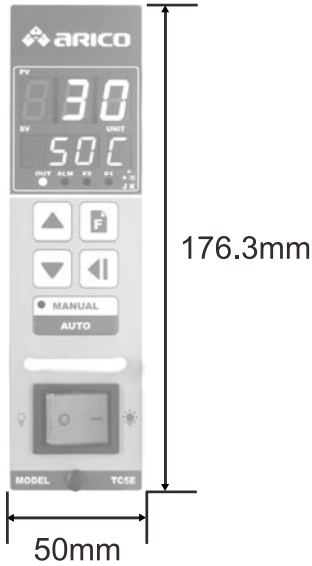

Deviation: ±5mm

# 1-4 Operating description

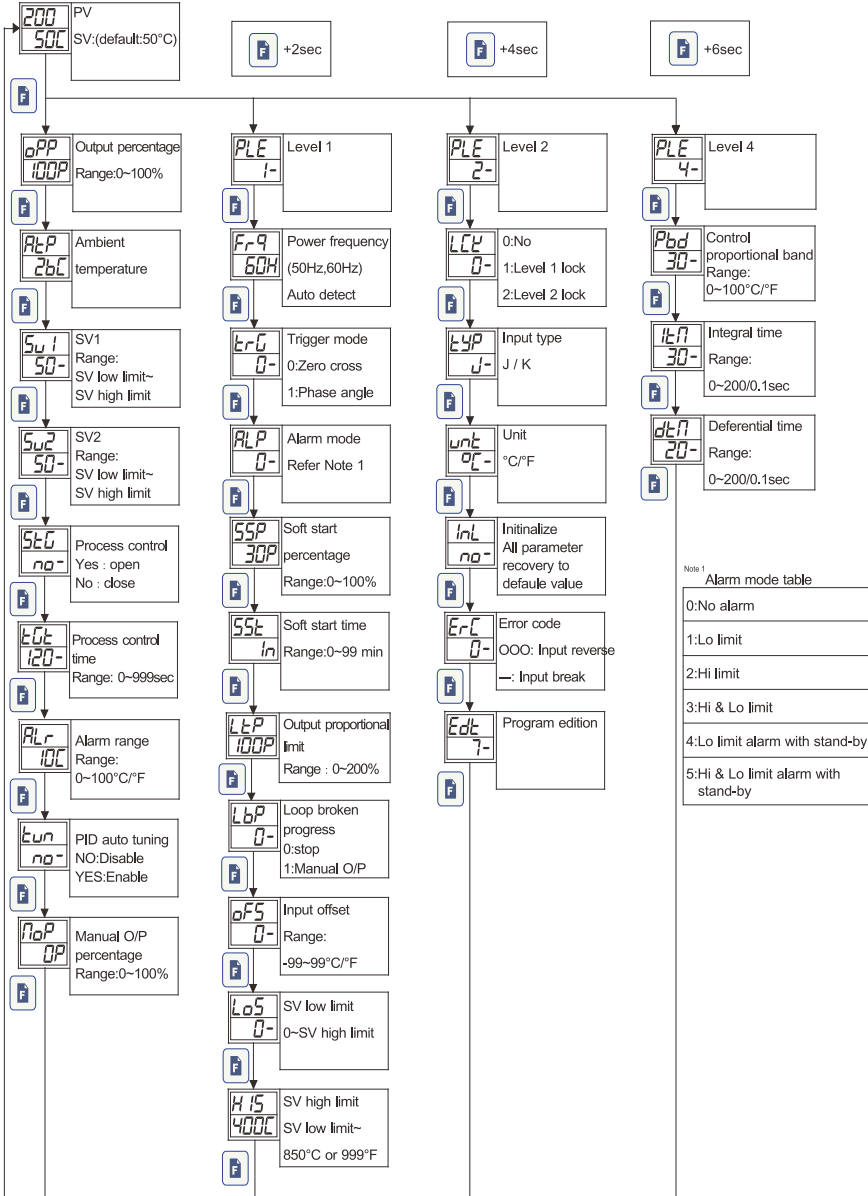

## 1-4-1 Parameter flow chart





## 1-4-2 Operating modes

---

TC5E divide into Main mode and parameter mode. In main mode, press  could entry parameter mode.

Main mode: Controller display PV and SV, use  for SV modification.

Parameter mode: Controller display parameter name and its value, use  for value modification.

## 1-4-3 Control modes

---



Auto mode: The instrument make auto temperature control.

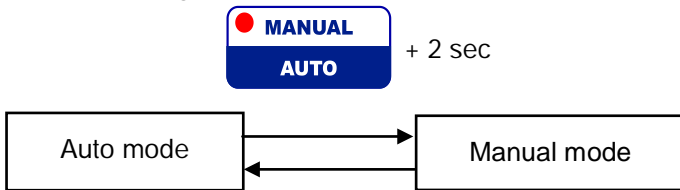

Manual mode: The instrument follow parameter  $P$  and make output.  
(UNIT field display "P")

Manual/Auto mode change



Exchange SV1 and SV2

 +  + 3 sec: SV1 temperature control.

 +  + 3 sec: SV2 temperature control.



※Execute SV2 temperature control indicator flash.

(Refer 1-3-1 faceplate description)

## 1-4-4 The alarm output function disable temporarily

---



 +  + 1 sec: The alarm output function disable or enable select (when power re-setting, the default setting is enable)

### 1-4-5 Soft start (Heater dehumidify) function

---

To avoid the humidity make the heater burn out. The soft start function could output a lower current to make dehumidify action when turn on the power.

Soft start condition:

The soft start percentage (*SSP*) and time (*SS<sub>t</sub>*). After power turn on, if  $SV > PV$  ;  $PV < 120^{\circ}\text{C}$ , manual and PID tuning function are disable, the soft start would be executed. Set *SS<sub>t</sub>* to zero for disable soft start function.

Soft start interrupt:

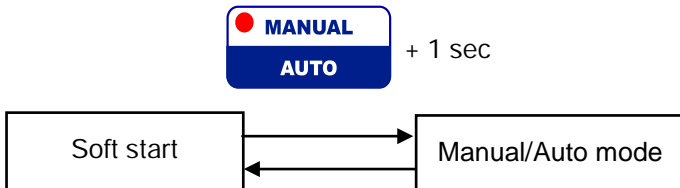

### 1-4-6 PID auto tuning function

---

For get the optimal PID value in some system, it is possible to execute "PID auto tuning" function when first use or heater system changed.

After finished auto tuning, the optimal PID would be save into the instrument Start PID auto tuning function:

- (1) PV must lower than  $120^{\circ}\text{C}$  or  $180^{\circ}\text{F}$
- (2) SV must higher than PV for  $80^{\circ}\text{C}$  or  $100^{\circ}\text{F}$
- (3) Set parameter *t<sub>un</sub>* into *YES*

PS : During PID auto tuning execution, the decimal point of PV would flash.

After instrument get the optimal PID, the decimal point turn off and instrument recovery to auto temperature control.

## 1-4-7 Process control

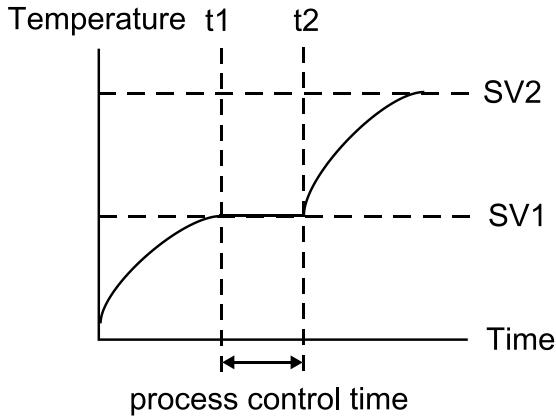

## 1-4-8 Error message

- (1) **■■■** : Input break
- (2) **000** : Input reverse

## 1-4-9 Wiring

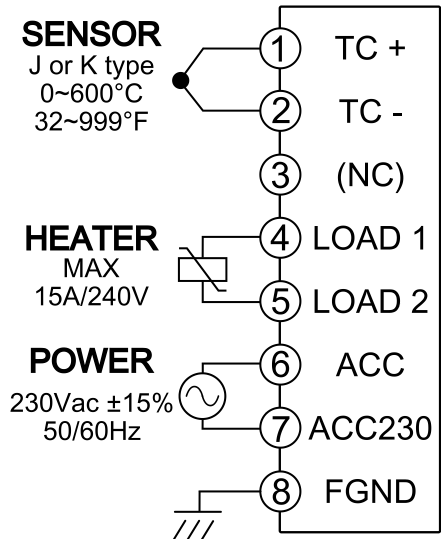

# Chapter 2 CABINET

## 2-1 Dimension

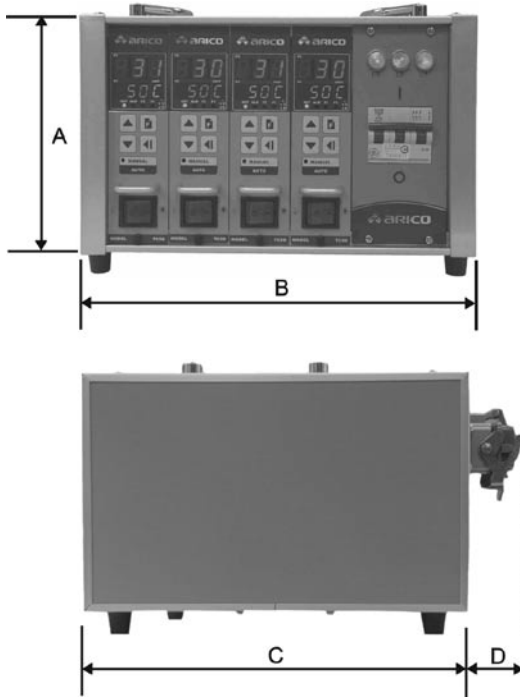

Unit: mm

Cabinet	A	B	C	D
1 Zones	188	96	248	30
2 Zones	215	223	299	45
4 Zones		323		
6 Zones		424		
8 Zones		524		
12 Zones		726		

## 2-2 Specification

Type	T5A01	T5A02	T5A04	T5A06	T5A08	T5A12
Zone Item	1	2	4	6	8	12
Power Switch capacity(A)	--	32	32	63	63	63
Output Connector	4pin+E (ground)	16pins x1	16pins x1	24pins x1	16pins x2	24pins x2
Power Cable	2.0mm <sup>2</sup> x3C x3M	5.5mm <sup>2</sup> x5C x3M	5.5mm <sup>2</sup> x5C x3M	8.0mm <sup>2</sup> x5C x3M	8.0mm <sup>2</sup> x5C x3M	8.0mm <sup>2</sup> x5C x3M
Weight(kg) (non-module)	1.75	7.25	9	11.25	12.5	16

## 2-3 Connection description

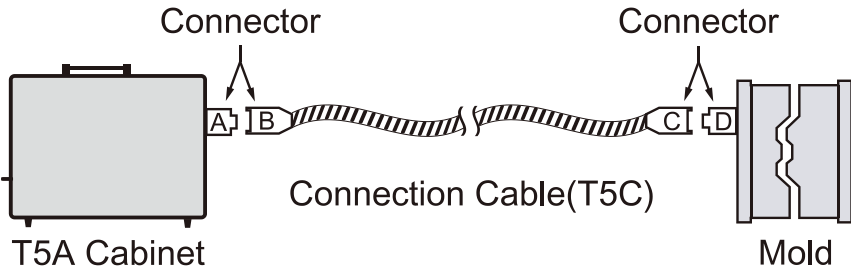

### Connector type

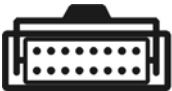

a: single hook

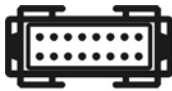

c: dual hook



b: single button



d: dual button

Connector	A	B	C	D
Name	Housing	Hood	Hood	Housing
	T5E	T5F	T5F	T5E
Type	Socket	Plug	Socket	Plug
Combination	1*	a	b	A
	2	c	d	C
	3	d	c	d

\*Standard type

\*\*T5A01 only for type 1

## 2-4 Type of power wiring

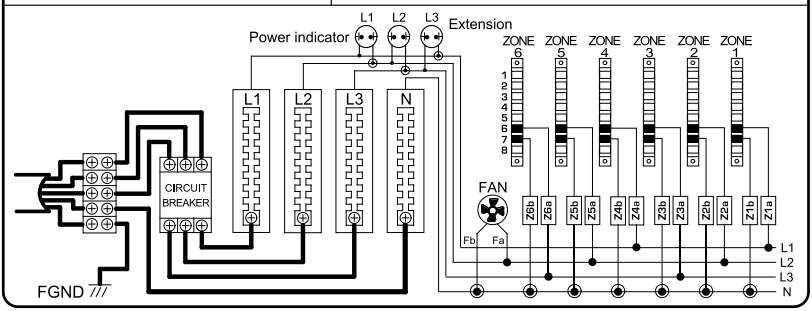
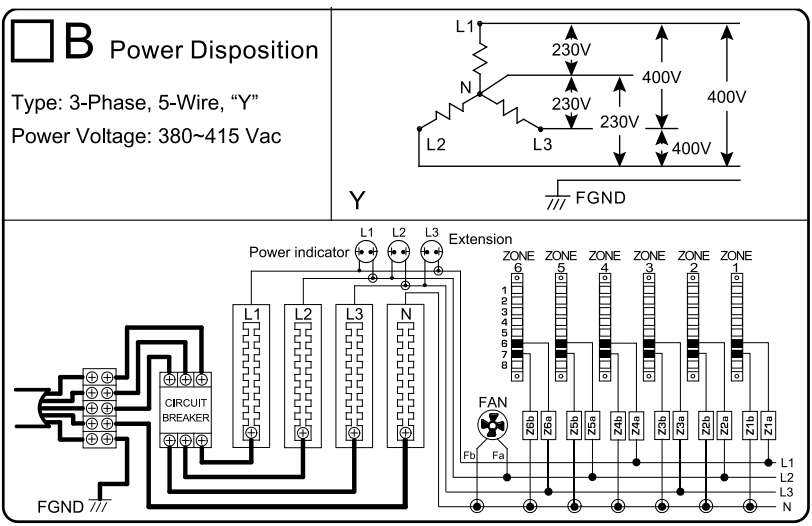
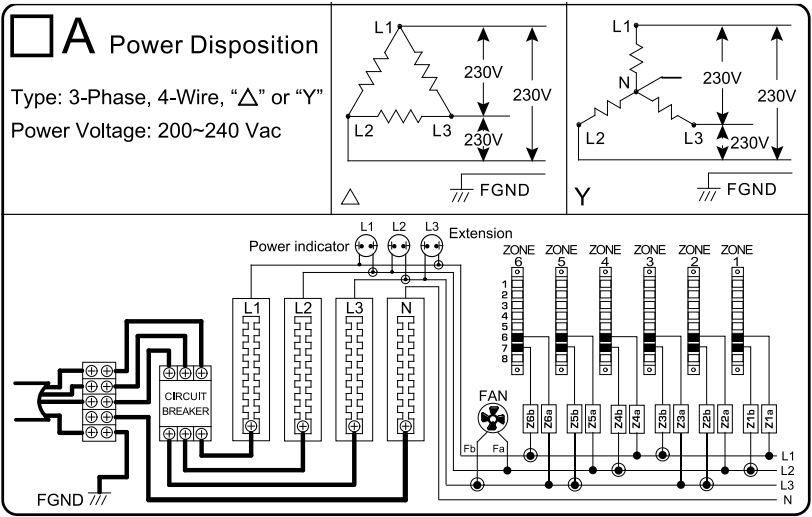

## The following power wiring only for T5A01

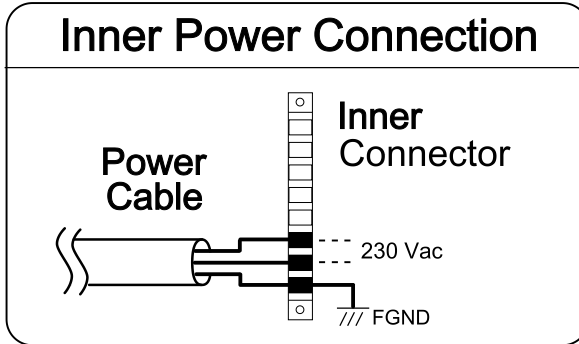

### Caution

1. Before operating, check connection ("y" or " $\Delta$ ") and its voltage.
2. All instruments must be used in accordance with the specification to prevent fire or damage to instrument and equipment.
3. Be sure the ac power input is switched off before maintenance.

Note: power type A and B differ with regard to " $\bullet$ " connections.

**⚠** *The FGND must be connected with earth ground.*

## 2-5 Connector wiring

Cabinet connector wiring are divided into A, B and C type as below:

A type wiring

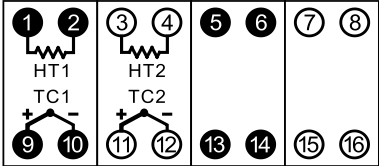
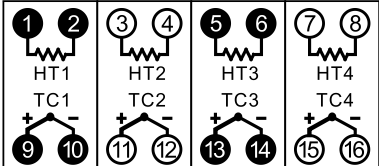
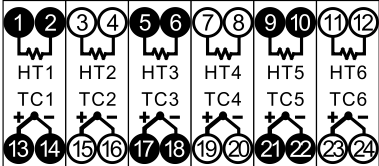
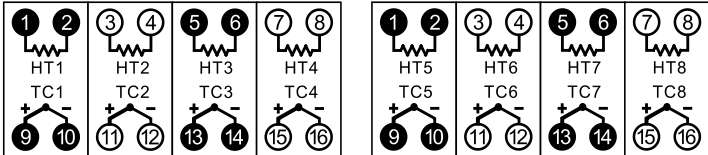
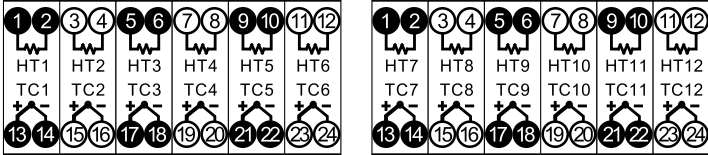
ZONE	CONN.	CONNECTOR ASSIGNMENT
2	16*1	
A16-2		
4	16*1	
A16-4		
6	24*1	
A24-6		
8	16*2	
A16-8		
12	24*2	
A24-12		

B type wiring

ZONE	CONN.	CONNECTOR ASSIGNMENT
2	16*1	
B16-2		
4	16*1	
B16-4		
6	24*1	
B24-6		
8	16*2	
B16-8		
12	24*2	
B24-12		



C type wiring

ZONE	CONN.	CONNECTOR ASSIGNMENT	
8	16*2		
C16-8			
12	24*2		
C24-12			

# Chapter 3 ORDER CODE

## 3-1 Cabinet: T5A

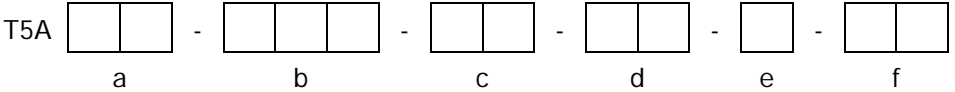

- |               |                          |                               |
|---------------|--------------------------|-------------------------------|
| a : Zone      | d : Power Cable Length   | f : Cable Wiring              |
| 01 : 1 zone   | 03 : 3m (standard)       | 00 : Without connection cable |
| 02 : 2 zones  | e : O/P Connector Wiring | 03 : 3m (standard)            |
| 04 : 4 zones  | A : A type               |                               |
| 06 : 6 zones  | B : B type               |                               |
| 08 : 8 zones  | C : C type               |                               |
| 12 : 12 zones |                          |                               |

- b : Housing and Hood
- SHB : Housing is single hook, hood is single button\*
  - DHB : Housing is dual hook, hood is dual button
  - DBH : Housing is dual button, hood is dual hook

- c : Power Wiring
- A0 : A type 3-phase 4-wire 200~242VAC
  - B0 : B type 3-phase 5-wire 380~415VAC
  - A1 : A type 3-phase 4-wire 200~242VAC\*
  - B1 : B type 3-phase 5-wire 380~415VAC\*

\* : For 1 zone T5A01

## 3-2 Cable: T5C

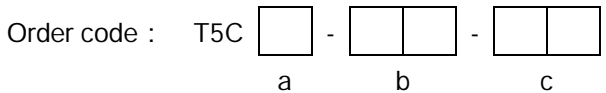

- a: Wiring
- b: Pins--4, 16, 24
- c: Length(M)

©Standard Length 3M

### 3-3 Housing: T5E

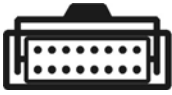

Single hook



Single button

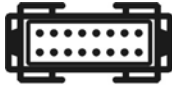

Dual hook



Dual button

Order code : T5E 

--	--

 - 

--

  
a b

a: Pins--4, 16, 24

b: Type

1:Single hook

2: Dual hook

3:Single button

4: Dual button

### 3-4 Hood: T5F

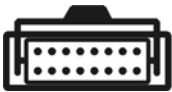

Single hook



Single button

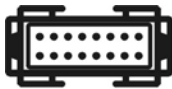

Dual hook



Dual button

Order code : T5F 

--	--

 - 

--

  
a b

a: Pins--4, 16, 24

b: Type

1:Single hook

2: Dual hook

3:Single button

4: Dual button

### 3-5 Blank plate: T5G



Order code : T5G

### 3-6 Connector: T5D

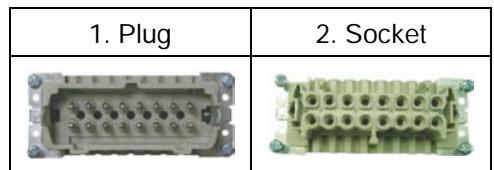

Order code : T5D 

--	--

 - 

--

  
a b

a: Pins--4, 16, 24

b: Type

1: Plug

2: Socket

## 3-7 Trouble shooting

Malfunction status	Check item
1.No action after power on.	<ul style="list-style-type: none"> <li>● TC5E is installed properly?</li> <li>● Power wiring is correct?</li> <li>● Main power switch is malfunction?</li> <li>● TC5E module is malfunction?</li> </ul>
2.F1 or F2 fuse break indicator bright.	<ul style="list-style-type: none"> <li>● Change the fuse accord with the brightly indicator.</li> </ul>
3.Display " ■ ■ ■ "	<ul style="list-style-type: none"> <li>● TC5E is installed properly?</li> <li>● Thermocouple is break?</li> <li>● Extension cable is loose or breaks?</li> <li>● TC5E module is malfunction?</li> </ul>
4.Display " 000 "	<ul style="list-style-type: none"> <li>● Thermocouple is reverse?</li> <li>● TC5E module is malfunction?</li> </ul>
5.No display PV normally or PV unstable.	<ul style="list-style-type: none"> <li>● Refer item 3.</li> <li>● Power leakage?</li> <li>● The ground is properly?</li> </ul>
6.In the normal operation, the temperature cannot rise up.	<ul style="list-style-type: none"> <li>● TC5E is installed properly?</li> <li>● Extension cable is loose or breaks?</li> <li>● Heater is malfunction?</li> <li>● TC5E(TRIAC) is malfunction?</li> </ul>
7.Temperature control is unstable.	<ul style="list-style-type: none"> <li>● Refer 1-4-5, execute PID self-tuning.</li> </ul>



長新科技股份有限公司

ARICO Technology Co., Ltd.

總公司(HEADQUARTERS)

23145新北市新店區寶橋路235巷1弄1號8樓

8F., No. 1, Alley 1, Lane 235, Baoqiao Rd., Xindian Dist., New Taipei City, 23145, Taiwan

TEL:+886-2-29101266 FAX:+886-2-29159434

[www.arico.tw](http://www.arico.tw) / [www.arico.com.tw](http://www.arico.com.tw)